

□ IN INCHES

MACHINE DIVIDED INTO TWO PARTS FOR HANDLING (PART A + PART B)

UNLESS OTHERWISE SPECIFIED, ALL DIMENSIONS ARE IN MILLIMETERS		SURFACE FINISH:		PROJECTION: ISO-E		SEMIPRODUCED MATERIAL	
				TOLERATION: ISO 2768 m K		PROTECTED ACCORDING TO ISO 16016	
				ACCURACY: ISO 8015			
NAME	SIGNATURE	DATE	NAME	SIGNATURE	DATE	NAME	
DRAWN BY: ING. TOMÁŠ MIVALT		CHANGED	ponořil 27. ledna 2014		ponořil 1. února 2021	MP-DW-403	
				ASSEMBLY NO: T-04c			
				MATERIAL:		DRAWING NO: T-04c_07	
				www.mivalt.cz		A3	
				MASS: 3992913,39 g		SCALE: 1:20	
						SHEET 1 FROM 3 SHEETS	

DOPORUČENÝ MANIPULAČNÍ PROSTOR
RECOMMENDED SPACE

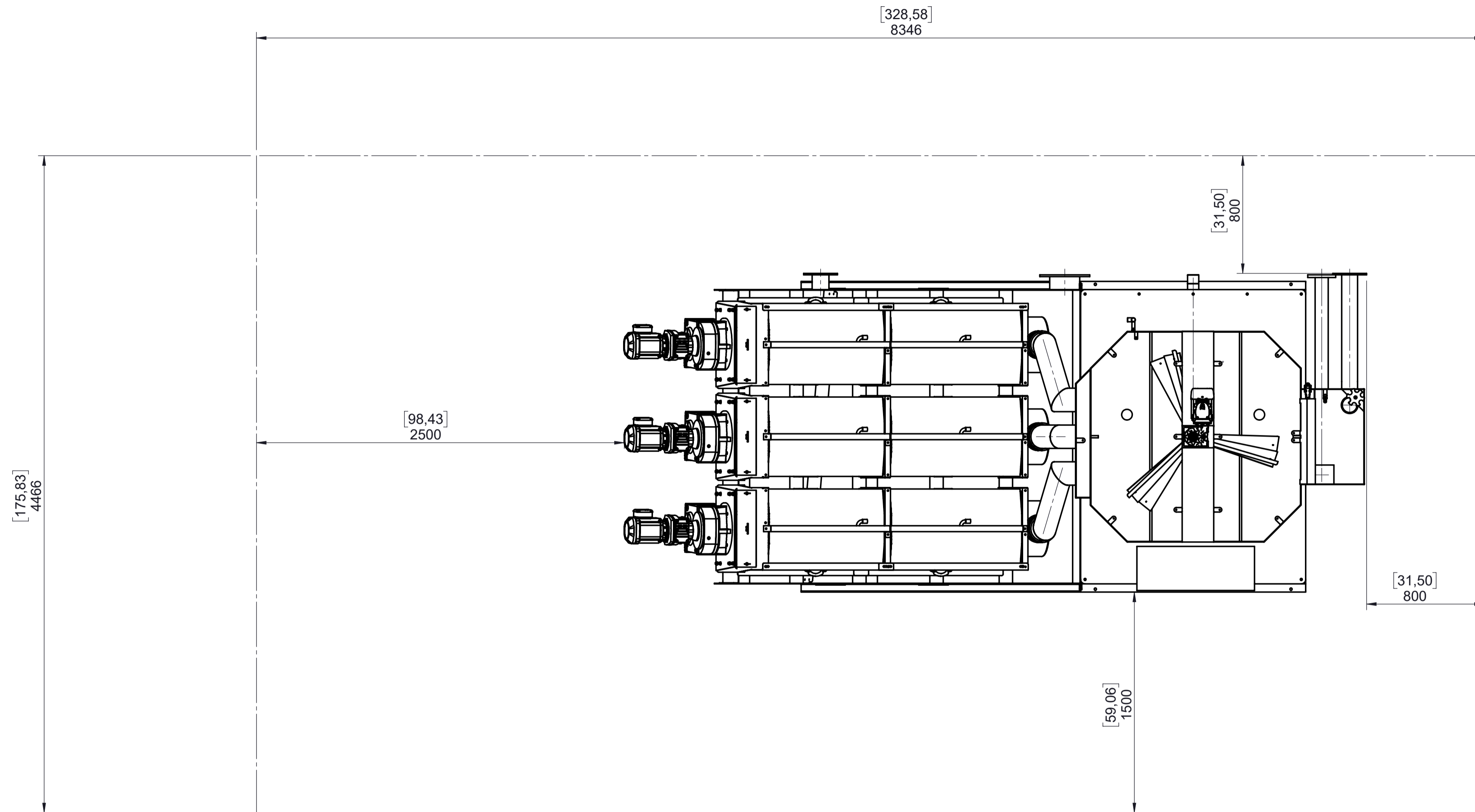

IN INCHES

UNLESS OTHERWISE SPECIFIED, ALL DIMENSIONS ARE IN MILLIMETERS		SURFACE FINISH:		PROJECTION: ISO-E		SEMIPRODUCED MATERIAL	
				TOLERANCE: ISO 2768 m K		PROTECTED ACCORDING TO ISO 16016	
				ACCURACY: ISO 8015			
NAME	SIGNATURE	DATE	NAME	SIGNATURE	DATE	NAME	
DRAWN BY: ING. TOMÁŠ MÍVALT		CHANGED	pondělí 27. ledna 2014		pondělí 1. února 2021	MP-DW-403	
			ASSEMBLY NO: T-04c				
MATERIAL:		DRAWING NO: T-04c_07		SCALE: 1:20		A3	
www.mivalt.cz		MASS: 3992915,39 g		SHEET 2 FROM 3 SHEETS			

KOTEVNÍ BODY
ANCHOR POINTS

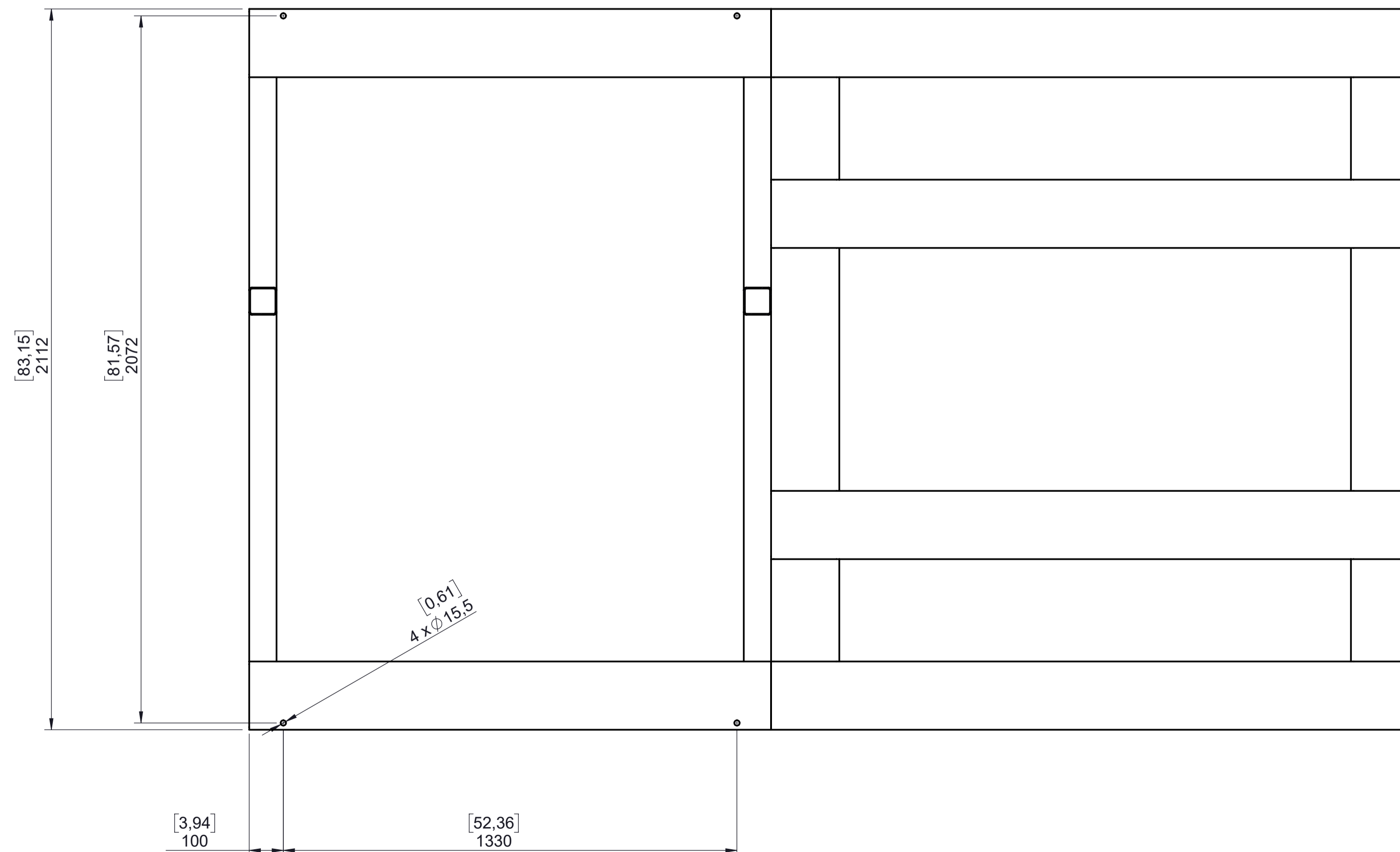
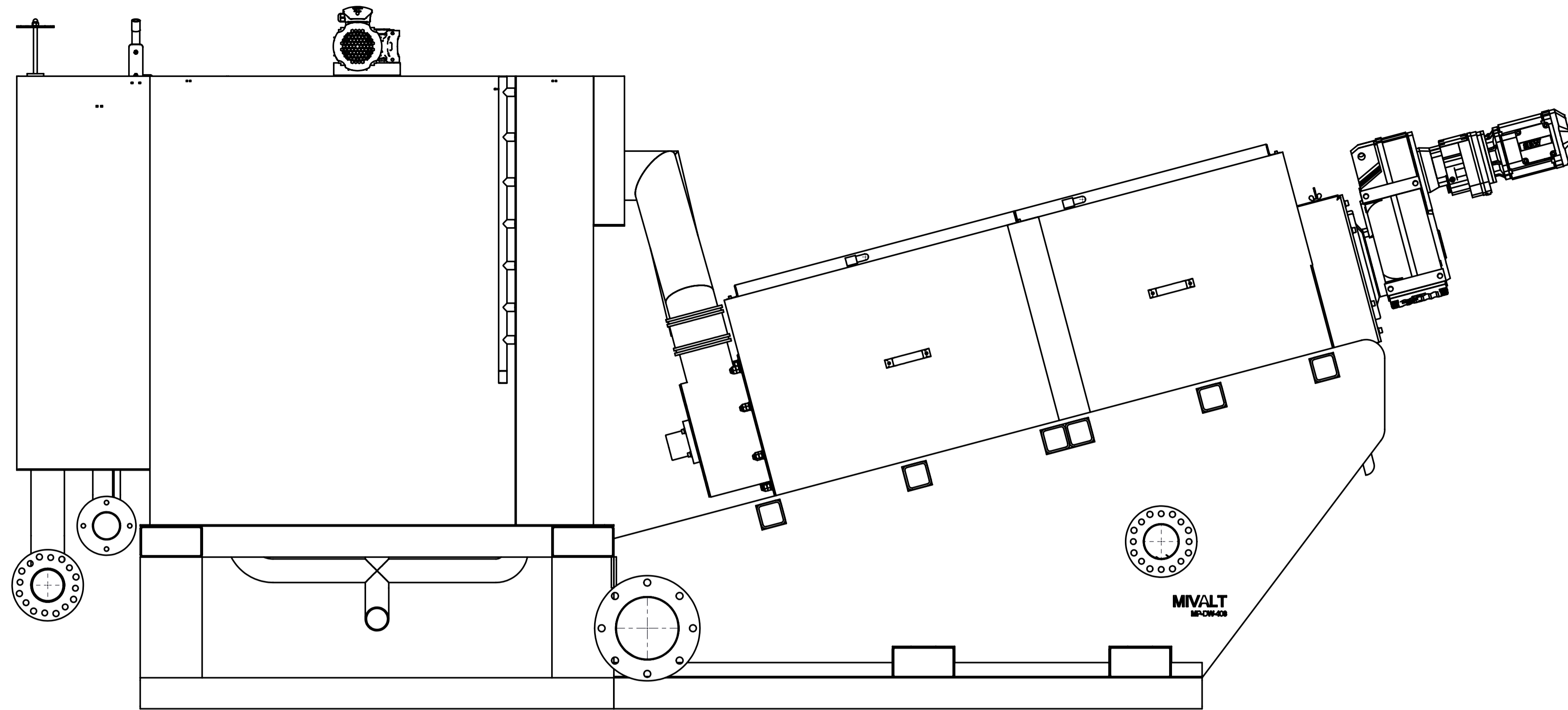

IN INCHES

UNLESS OTHERWISE SPECIFIED, ALL DIMENSIONS ARE IN MILLIMETERS		SURFACE FINISH:		PROJECTION: ISO-E		SEMIPRODUCED MATERIAL	
				TOLERATION: ISO 2768 m K		PROTECTED ACCORDING TO ISO 16016	
				ACCURACY: ISO 8015			
NAME	SIGNATURE	DATE	NAME	SIGNATURE	DATE	NAME	
DRAWN BY: ING. TOMÁŠ MIVALT		CHANGED	ponořil 27. ledna 2014		ponořil 1. února 2021	MP-DW-403	
			ASSEMBLY NO: T-04c				
MATERIAL:		DRAWING NO: T-04c_07		SCALE: 1:10		SHEET 3 FROM 3 SHEETS	
www.mivalt.cz		MASS: 399015.39 g				A3	