

□ in inches

UNLESS OTHERWISE SPECIFIED, ALL DIMENSIONS ARE IN MILLIMETERS		SURFACE FINISH:		PROJECTION: ISO-E		SEMI-PRODUCED MATERIAL	
				TOLERANCE: ISO 2768 m K		<b>PROTECTED ACCORDING TO ISO 16016</b>	
				ACCURACY: ISO 8015		NAME:	
DRAWN BY: ING. TOMÁŠ MÍVALT		SIGNATURE:		DATE: středa 4. prosince 2013		<b>MP-DW-131</b>	
		CHANGED:		čtvrtek 28. ledna 2021		DRAWING NO: T-01-00_12	
		ASSEMBLY NO: T-01-00		MATERIAL:		SCALE: 1:20	
<b>MIVALT</b> obchodní společnost		www.mivalt.cz		MASS: 337042.49 g		SHEET 1 FROM 3 SHEETS	
						A3	

# DOPORUČENÝ MANIPULAČNÍ PROSTOR RECOMMENDED SPACE

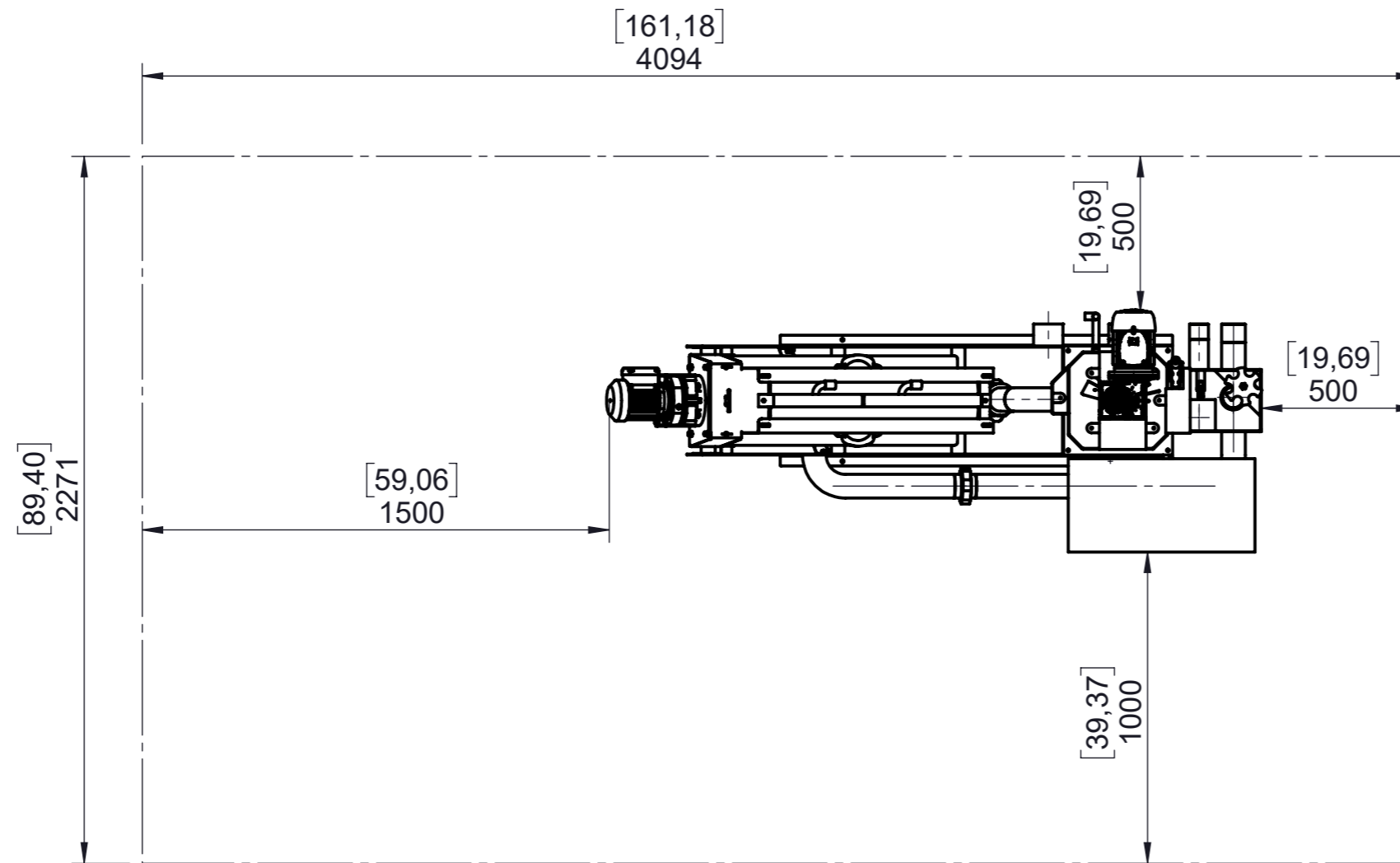

□ in inches

UNLESS OTHERWISE SPECIFIED, ALL DIMENSIONS ARE IN MILLIMETERS		SURFACE FINISH:		PROJECTION: ISO-E	SEMI-PRODUCED MATERIAL
				TOLERANCE: ISO 2768 m K	<b>PROTECTED ACCORDING TO ISO 16016</b>
				ACCURACY: ISO 8015	
DRAWN BY	NAME	SIGNATURE	DATE	středa 4. prosince 2013	NAME:
	ING. TOMÁŠ MÍVALT		CHANGED	čtvrtek 28. ledna 2021	<b>MP-DW-131</b>
				ASSEMBLY NO:	T-01-00
				MATERIAL:	DRAWING NO:
www.mivalt.cz				MASS: 337042.49 g	T-01-00_12
				SCALE: 1:20	A3
				SHEET 2 FROM 3 SHEETS	

# KOTEVNÍ BODY ANCHOR POINTS

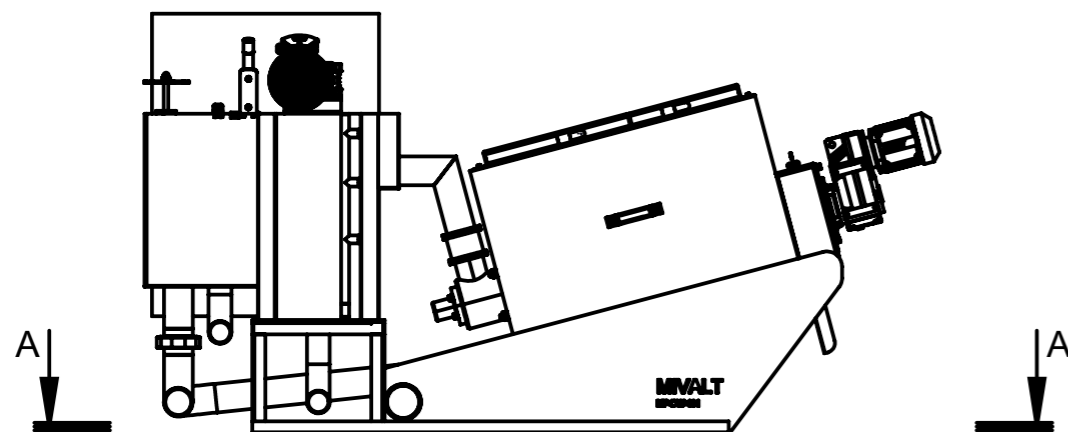
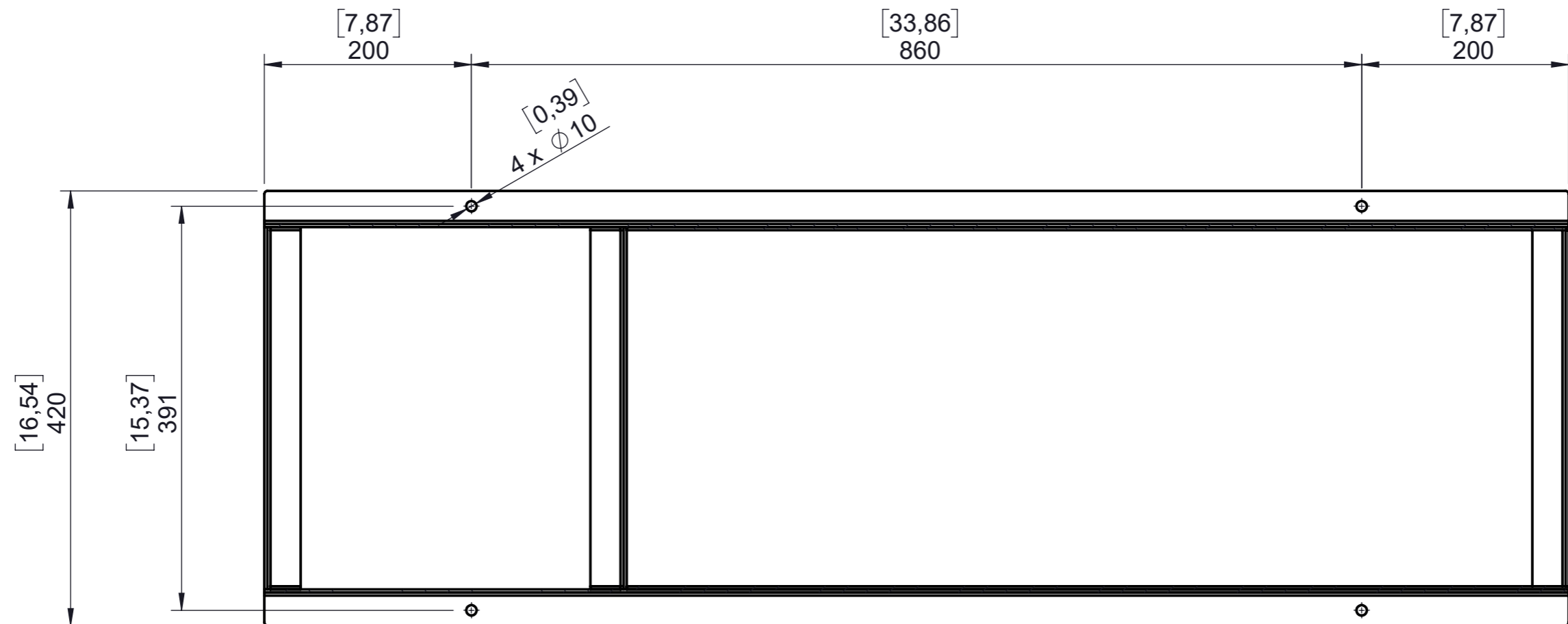

□ in inches

UNLESS OTHERWISE SPECIFIED, ALL DIMENSIONS ARE IN MILLIMETERS		SURFACE FINISH:		PROJECTION: ISO-E	SEMI-PRODUCED MATERIAL
				TOLERANCE: ISO 2768 m K	<b>PROTECTED ACCORDING TO ISO 16016</b>
				ACCURACY: ISO 8015	
DRAWN BY: ING. TOMÁŠ MÍVALT		SIGNATURE:	DATE: středa 4. prosince 2013	NAME: <b>MP-DW-131</b>	
		CHANGED:	čtvrtek 28. ledna 2021	DRAWING NO: <b>T-01-00_12</b>	
		ASSEMBLY NO: T-01-00		SCALE: 1:20	
<b>MIVALT</b> obchodní společnost		MATERIAL:		SHEET 3 FROM 3 SHEETS	
www.mivalt.cz		MASS: 337042.49 g		A3	